

SFL122: Bulk Bag - Spout Top & Closed Bottom

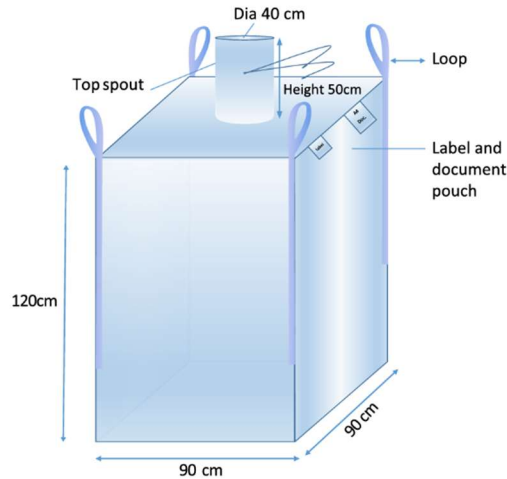

Suitable for food, pharmaceuticals, agriculture, chemicals, mining & minerals, fertilizer, cement, ash, waste & recycling and waterproof bulk bag requirements.

Bag size: 90 x 90 x 120 cm	Safe Working Load: 1250 kg
Test Certification: ISO 21898	Fabric GSM: 150
Safety Factor: 5:1	Liner: LDPE Inner Liner 80 (Sewn 8 corners with tabs)
Lamination: None	Loop length: 30 cm, width: 40 mm
Bag type: U-Panel construction with 4 corner loops	Fabric type: Circular woven
Fabric colour: White	Discharge: None (closed bottom).
Filling: Spout diameter 40 x 50 cm with white web tie (2 x 50 cm).	Bag weight: 2255 grams (+/-4%)
Sewing thread: White	Pouch: A4 attached with top seam.
Packing: 155 or 165 bags/pallet	UV Treated